











# Uninterrupted power supply (UPS) supercapacitor based- specifications



## SAFETY INFORMATION

-  The instructions in this manual cannot replace necessary training or adequate experience in the safe operation of the described equipment. Only competent technicians who are familiar with this equipment should install, operate, and maintain it.
-  Refer to the installation instructions before connecting to the equipment to a power supply.
-  Overcurrent protection for the input must be provided externally.
-  It should be installed in a room without pollution and with good heat dissipation.
-  The disconnect device is provided other suppliers.
-  The circuit is not isolated from the input, and there may be a dangerous voltage between the terminal and the ground. Test before touching.
-  An unexpected short circuit in an energy storage supercapacitor can produce high temperatures that can cause equipment damage and severe burns.

### Hazard Statement Definitions

	CAUTION:Indicates a potentially hazardous situation which, if not avoided, may result in minor or moderate injury.
	WARNING: Indicates an imminently hazardous or serious injury.
	DANGER: Indicates a potentially hazardous death or serious injury.

**Revision records of the manual**

<b>Date</b>	<b>Version</b>	<b>Change Description</b>	<b>Prepared by</b>
2024-12- 21	A01	First Edition	Sherry
2025-7- 8	A02	Add certification information	Sherry

# Catalog

<b>1. Scope of Application</b> .....	<b>5</b>
<b>2. Product Introduction</b> .....	<b>5</b>
2.1. Product Introduction .....	5
2.2. Supercapacitor Module .....	5
2.3. Charge and Discharge Management System .....	5
<b>3. Technical parameter</b> .....	<b>6</b>
3.1. Basic Parameters .....	6
3.2. Other Optional Features .....	9
3.3. Schematic diagram of the internal structure .....	10
<b>4. Installation</b> .....	<b>10</b>
4.1. Dimensions (Unit: mm) .....	10
4.2. Installation Method .....	11
<b>5. Precaution</b> .....	<b>11</b>

## 1. Scope of Application

This document applies to the Mini UPS series supercapacitor energy storage backup power supply products. It provides detailed explanations on the product's functions, performance, structure, usage methods, and precautions.

## 2. Product Introduction

### 2.1. Product Introduction

The Mini UPS Series is engineered to solve the problem of unstable power supply lines for PLCs, industrial control hosts, and automation control units. When voltage sags during operation cause control units to lose power, the UPS unit provides instant compensation to prevent system restarts. After power outage, it supplies emergency energy to preserve field data and ensure safe shutdown. Featuring a mature power management chip and high-performance supercapacitor, this product delivers reliable power supply and protection, significantly enhancing system stability.

### 2.2. Supercapacitor Module

The system utilizes supercapacitor modules to store electrical charge. When the main power supply fails, these modules can rapidly provide backup power to maintain normal operation, ensuring uninterrupted service during primary-standby power switching. With features like long lifespan, low-temperature resistance, and maintenance-free operation, supercapacitors are particularly suitable for industrial equipment requiring extended service life and with difficult maintenance access.

### 2.3. Charge and Discharge Management System

When the main power supply is normally input, the output can immediately deliver power to the load without waiting for the supercapacitor module to charge. Meanwhile, the charging control circuit automatically manages the supercapacitor module's charging process without disrupting the normal operation of the main power supply or the load. Upon detecting a main power outage, the system automatically switches to the backup power source to maintain power supply. During

capacitor charging, the balancing and protection circuit safeguards the capacitors, preventing damage and lifespan reduction caused by overvoltage.

### 3. Technical parameter

#### 3.1. Basic Parameters

Parameter \ Model	24V2A	24V3A	24V4A	24V5A	24V6A	24V8A
<b>Input</b>						
Rated Input Voltage DC (V)	DC24V					
Operating Voltage Range DC (A)	DC23~30V					
Maximum Input Current DC (A)	DC5A					
Charging Time Tc (s)	20					
Maximum Quiescent Current DC (mA)	15					
Capacitor Balancing Current DC (mA)	< 50					
<b>Output</b>						
Rated Output Voltage DC (V)	DC24V					
Rated Output Current DC (A)	2					
Instantaneous Current (A) @t<3s	4	6	8	10	12	16
Rated Buffer Time Td (s)	10					

Current When Fuse Breaks DC, (A)	4	6	8	10	12	/
Feature						
Protection Functions	Charging Current Limiting Reverse Protection Over-voltage Protection Overload Protection Short-circuit Protection Active Balancing			Charging Current Limiting Reverse Protection Over-voltage Protection Overload Protection Active Balancing		
Operating Altitude	< 2000m					
Operating Temperature	-40-65℃					
Operating Humidity	<95% no condensation					
Cycle Life	>500,000 times					
Overall Dimensions	88*54*59mm					
Weight	150g					
Certifications	EN55032:2015,EN IEC61000-3-2:2019,EN61000-3-3:2013,EN 55035:2017					

Model	12V2A	12V3A	12V4A	12V5A	12V6A	12V8A
Parameter						
Input						
Rated Input Voltage DC (V)	DC12V					
Operating Voltage Range DC (A)	DC11~15V					
Maximum Input Current DC (A)	DC5A					
Charging Time Tc (s)	10					

Maximum Quiescent Current DC (mA)	15					
Capacitor Balancing Current DC (mA)	< 50					
Output						
Rated Output Voltage DC (V)	DC12V					
Rated Output Current DC (A)	2					
Instantaneous Current (A) @t<3s	4	6	8	10	12	16
Rated Buffer Time Td (s)	10					
Current When Fuse Breaks DC, (A)	4	6	8	10	12	/
Feature						
Protection Functions	Charging Current Limiting Reverse Protection Over-voltage Protection Overload Protection Short-circuit Protection Active Balancing			Charging Current Limiting Reverse Protection Over-voltage Protection Overload Protection Active Balancing		
Operating Altitude	< 2000m					
Operating Temperature	-40-65℃					
Operating Humidity	<95% no condensation					
Cycle Life	>500,000 times					
Overall Dimensions	88*54*59mm					
Weight	150g					

Certifications	EN55032:2015,EN IEC61000-3-2:2019,EN61000-3-3:2013,EN 55035:2017
----------------	--

### 3.2. Other Optional Features

Model Parameter	Mini UPS -T	Mini UPS -B	MiniUPS-24V	MiniUPS-12V
Power Failure Delay	Optional Duration ; Maximum not exceeding buffer time.			
Power Failure Signal output		Dry contact output for power failure		
Optional Built-in Capacity			0.6F/1.1F/2.2F/2.7F	1.1F/2.2F/4F/5F
Optional External Capacity			Please select optional configurations as needed. Please contact our sales team in advance to confirm specifications.	

### 3.3. Schematic diagram of the internal structure

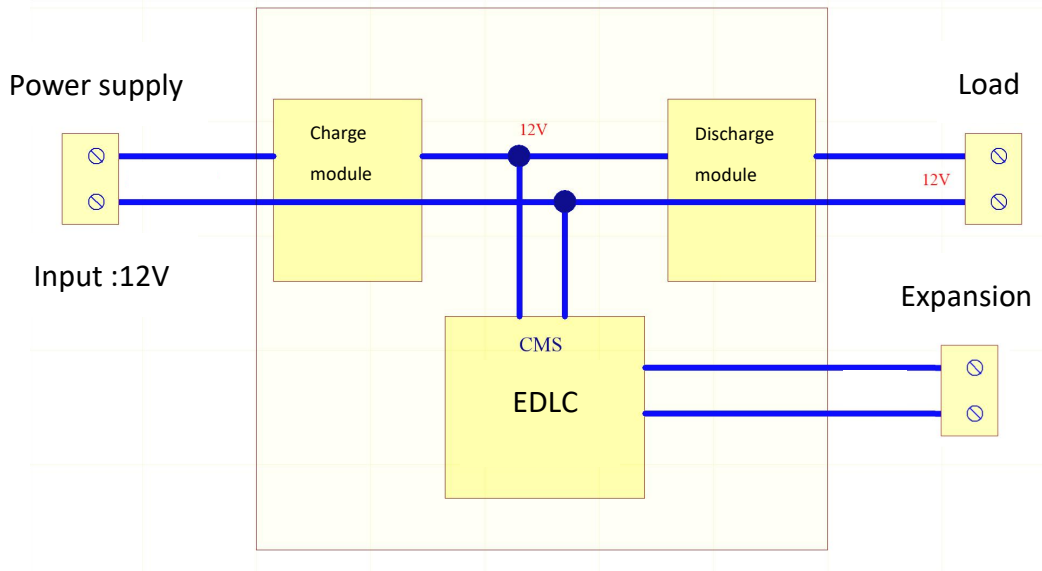

(12V as an example)

## 4. Installation

### 4.1. Dimensions (Unit: mm)



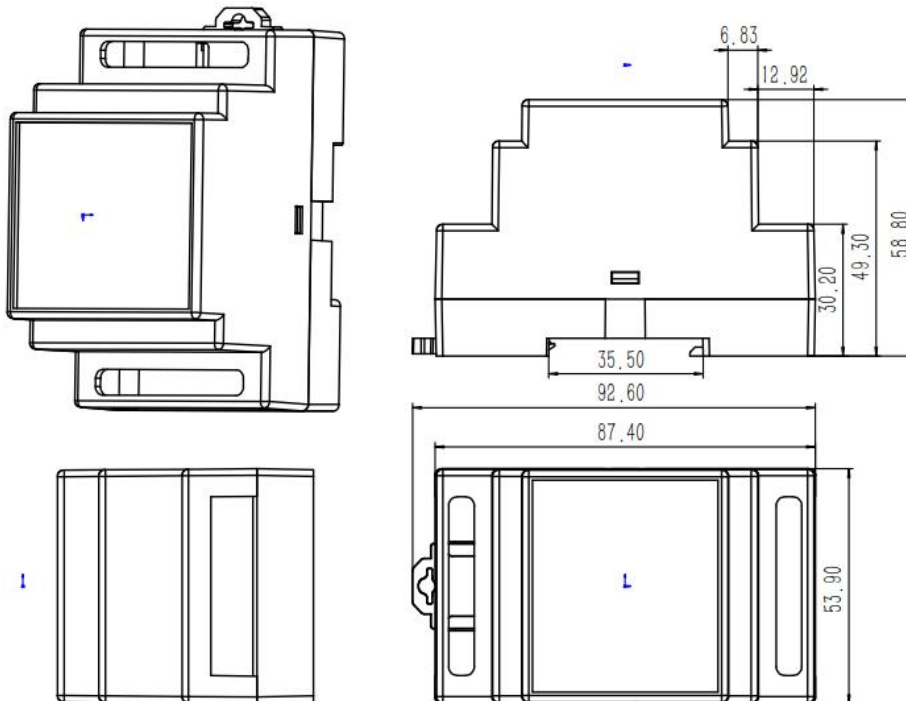



If you need a 3D product model, request it free of charge from your dealer.



## 4.2. Installation Method

The system uses standard DIN rails for installation without requiring additional accessories. These rails must comply with the EN60175-TH35 standard, featuring a width of 35mm and a height of 15mm.

## 5. Precaution

-  This device has a current limiting feature for charging.
-  This device features a bypass design that maintains power supply to the load during charging. The power supply must provide sufficient capacity to meet both load and charging demands, with a minimum 25% redundancy.
-  This device uses a non-isolated power supply. To enable isolation, install a power isolator before the input terminal.
-  This device features a built-in anti-backflow diode. The main power supply connects to the UPS output, while the UPS's load terminal links all downstream loads. It cannot provide backup power to devices before the input terminal.
-  During testing, note that the boost output will stop when the capacitor voltage drops below 6V, though the output voltage will still match the remaining capacitor voltage (except for devices with delayed power-off functionality). At this point, avoid forcing the discharge to exceed 1A. The standard practice is to discharge continuously through an electronic load in CC mode or resistors at rated current, but this method is not recommended and may cause damage. Discharge should cease when the output voltage reaches the load's minimum operating voltage.
-  To discharge the capacitor, connect an electronic load or resistor to the discharge terminal, allowing current to drop to 0V with a maximum of 1A. This process won't compromise the supercapacitor's charge-discharge performance or lifespan.



**TG-EP** Shenzhen Tringo Control Co., Ltd.

Company add (RD center): 403-405, Bldg.4, Nantai Yunchuang Valley, Fenghuang Str., Guangming Dist., Shenzhen, CN

Url: [www.tg-ep.com](http://www.tg-ep.com)

Our company reserves the right to modify the equipment parameters without prior notice.